

ENC1210-BS

Digital Signage Media Player Enclosure

MEGAMEDIA 

• INDUSTRIAL •

BrightSign®

The Mega Media Industrial ENC1210-BS is a custom weather resistant and security enclosure specifically designed and engineered for digital signage media players like the BrightSign XT4 and XD5 series.

Rugged and Water Resistant

Built with powder coated, fully welded steel with sealed gaskets, hidden hinges and installed using pre-drilled 3/8" holes.

Ready for Install

Customizable and removable back plate ships ready for mounting a BrightSign XT or XD player, but can be modified to fit any media player.

Includes two vent plugs, two IP54 rated cord grips, stainless steel player mounting fasteners and square key.

Maintenance free, easy installation, safe and secure.

Must use PoE for digital media player.

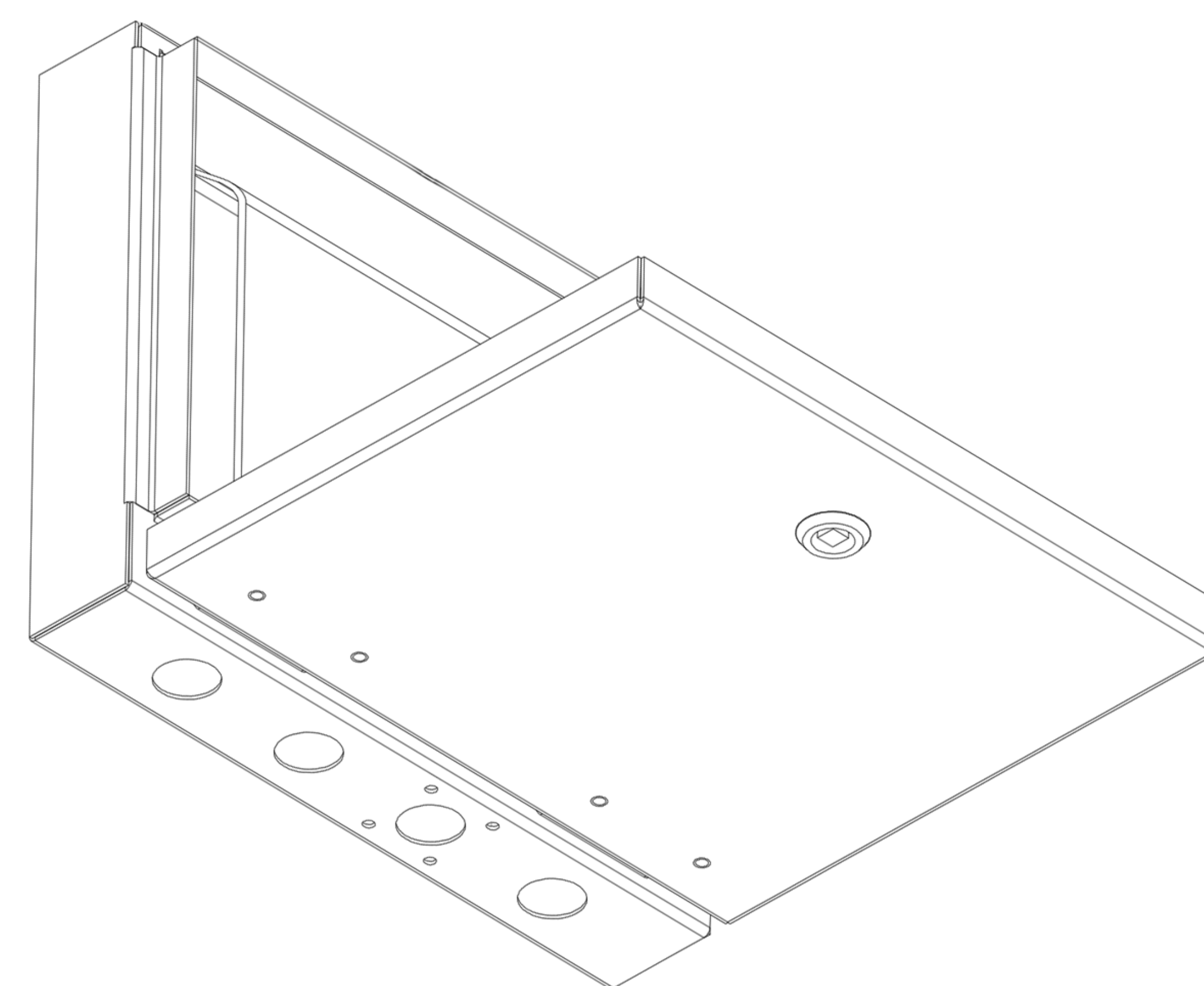
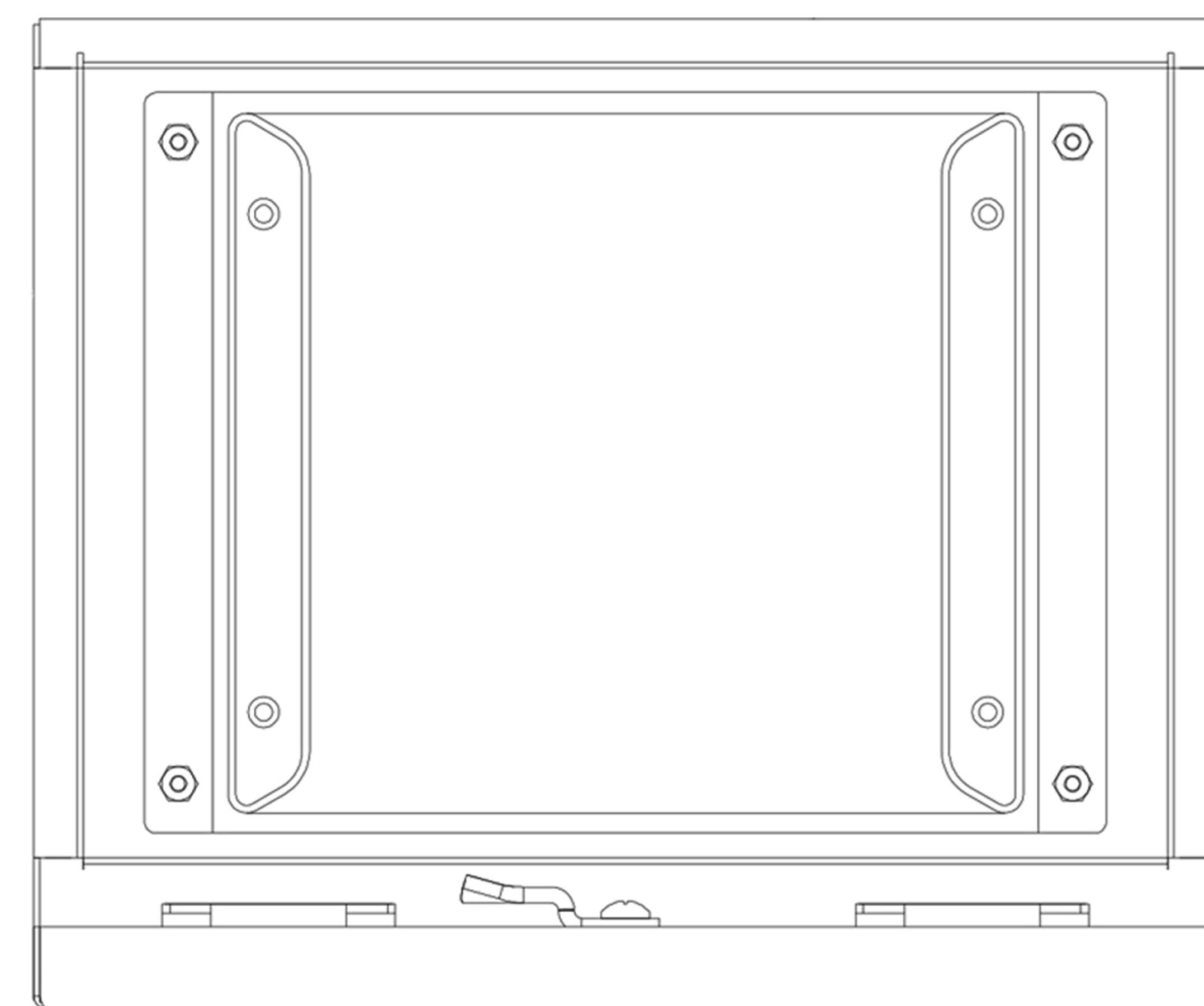

FEATURES

- ✓ Fully Welded Steel
- ✓ Hidden Hinges
- ✓ Sealed Gaskets
- ✓ Maintenance Free



Dimensions: 12" x 10" x 3" Weight: 8.5 lbs Made in the USA

